

Part number Codice prodotto	V in DC	P out W @24Vdc	I out DC max	Efficiency	ta °C	tc °C
A40DALI1103B	24	288	12 A	98%	-10...+40	70

Features

- IP20 independent interface
- Can be controlled by low voltage 24Vdc or 230Vac 50Hz push button
- Supplied with terminal cover and cable retainer

Caratteristiche

- Interfaccia indipendente IP20
- Controllabile tramite pulsante a bassa tensione 24Vdc o pulsante a 230Vac 50Hz
- Fornito di coprimorsetto e serracavo

Other technical data / Altri dati tecnici

Rated Voltage / Tensione nominale:	24 Vdc
Nominal life-time / Durata di vita nominale:	50000h @Ta 40 °C
Light control / Controllo della luce:	DALI 2/ PUSH BUTTON / 0-10V / 1-10V or 47K Potentiometer
Primary side terminal block / Morsetto lato primario:	1 x 0,5...2,5 mm ²
Primary side strain relief for cables / Serracavo lato primario:	Ø 4...9 mm ²
Secondary side terminal block / Morsetto lato secondario:	1 x 0,5...2,5 mm ²
Secondary side strain relief for cables / Serracavo lato secondario:	Ø 4...9 mm ²

Directives / Direttive: 2014/35/EU (LVD); 2014/30/EU (EMC); RoHS 2011/65/EU + 2015/863/EU (RoHS)

Standards compliance: EN 61347-2-13:2014 + A1:2017; EN 61347-1:2015

Conformità alle norme: EN 55015:2019 + A11:2020

EN IEC 63000:2018

IEC 62386-102:2014 + AMD1:2018; IEC 62386-207:2018

Operating mode selection / Selezione modalità operativa

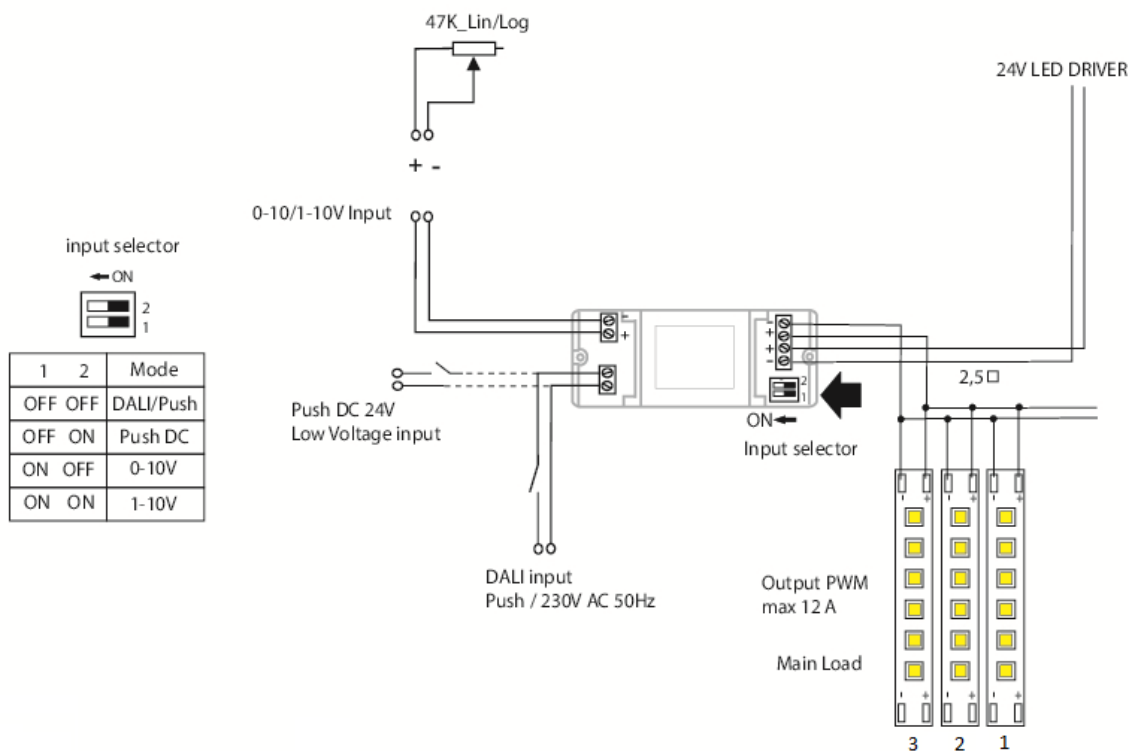

Product dimensions

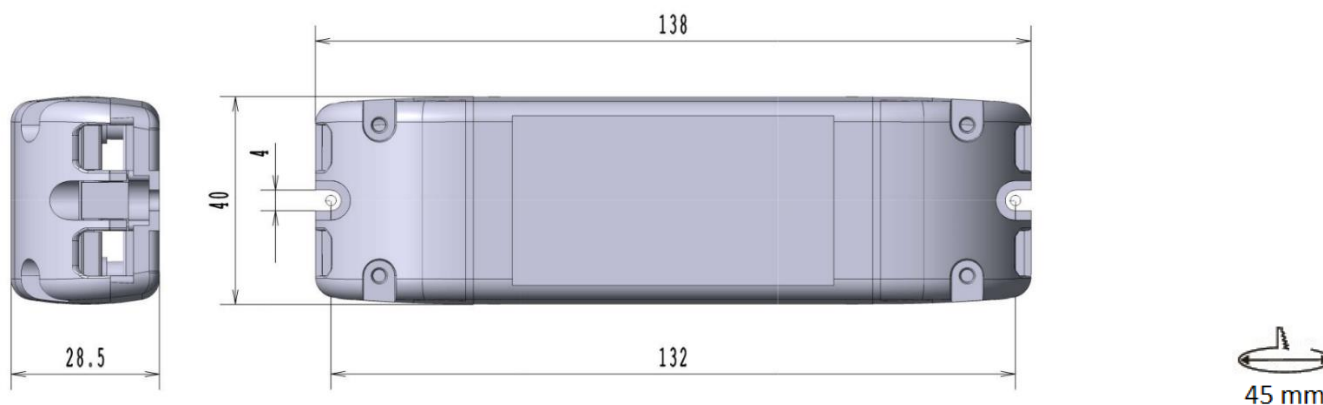

Weight / piece – Peso / pezzo

A40DALI1103B	95 gr.
--------------	--------

Istruzioni di montaggio Interfaccia DALI1103

Circuito a bassa tensione, collegare l'ingresso ad un alimentatore SELV o SELV equiv. Utilizzare cavi di sezione adeguata al carico fino a 4mm per carichi elevati. Collegare un carico resistivo quali strisce a Led o moduli Led rispettando il carico massimo. In caso di regolazione di lampadine a Led verificare che siano del tipo regolabile e con fattore di potenza elevato. L'interfaccia introduce una perdita di circa 0,3V sul carico a piena potenza. Collegamenti con polarità invertita possono danneggiare l'apparecchio o il carico. Utilizzare collegamenti corti e lontani dalle linee a tensione elevata.

Installation instructions for Interface DALI1103

Low voltage circuit, connect input to a SELV or SELV equivalent driver. Cables should have a suitable section for the load, up to 4 sqmm for high loads. Connect a resistive load, such as Led strips or led modules respecting the maximum rated load. When dimming Led bulbs, please check first if they are dimmable or not and verify that their power factor is high. The interface has a loss of approximately 0,3V on the load at full power. Connections with reverse polarity can damage the device or the load. Check cable connections, they must be short and run far from high voltage lines.

Installationsanweisungen für DALI1103

Niedervoltbetrieb durch ein SELV oder SELV equiv LED-Konverter. Kabelquerschnitt in Bezug auf die betriebene Last bis max 4mm für hohe Lasten verwenden. Für Betrieb von ohmschen Lasten wie Led-Streifen oder -Modulen. Beim Dimmen von Led-Lampen immer prüfen, dass diese LED-Lampen dimmbar sind und hoch Leistungsfaktor haben. Dieses Interface bringt einen Verlust von 0,3V mit vollem Last mit. Anschlüsse mit umgekehrter Polarität könne Bei Tasterregulierung kurze Anschlüsse verwenden und diese entfernt von hohen Spannungslinien nehmen.

Instructions de montage interface DALI1103

Circuit basse tension, brancher l'entrée à une alimentation SELV ou équivalent SELV. Utiliser des câbles de section adaptée à la charge; jusqu'à 4mm pour des charges élevées. Connecter une charge résistante comme rubans Led ou modules Led en respectant la charge maximale. En cas de réglage d'ampoules Led vérifier qu'elles soient réglables et d'un facteur de puissance élevé. L'interface introduit une perte d'environ 0,3V sur la charge à pleine puissance. Des branchements avec les polarités inversées peuvent endommager l'appareil ou la charge. Réaliser des branchements courts et éloignés des lignes à tension élevée. Utiliser des connexions courtes et éloignées des lignes de haute tension.

Instrucciones de instalación para el interface DALI1103

Circuito de baja tensión, conectar la entrada a un driver SELV o equivalente SELV. Los cables deben tener una sección adecuada a la carga, hasta 4sqmm for cargas altas. Conectar una carga resistiva, como tiras de led o módulos de led respetando la carga máxima. Cuando se dimericen las bombillas de led por favor comprobar si son dimerizables o no, y verificar que su factor de potencia es alto. El interfaz tiene una pérdida de aproximadamente 0,3V en la carga a máxima potencia. Las conexiones con la polaridad cambiada pueden dañar el equipo o la carga. Compruebe la conexiones de los cables, tienen que ser cortos y estar lejos de líneas de alta tensión.

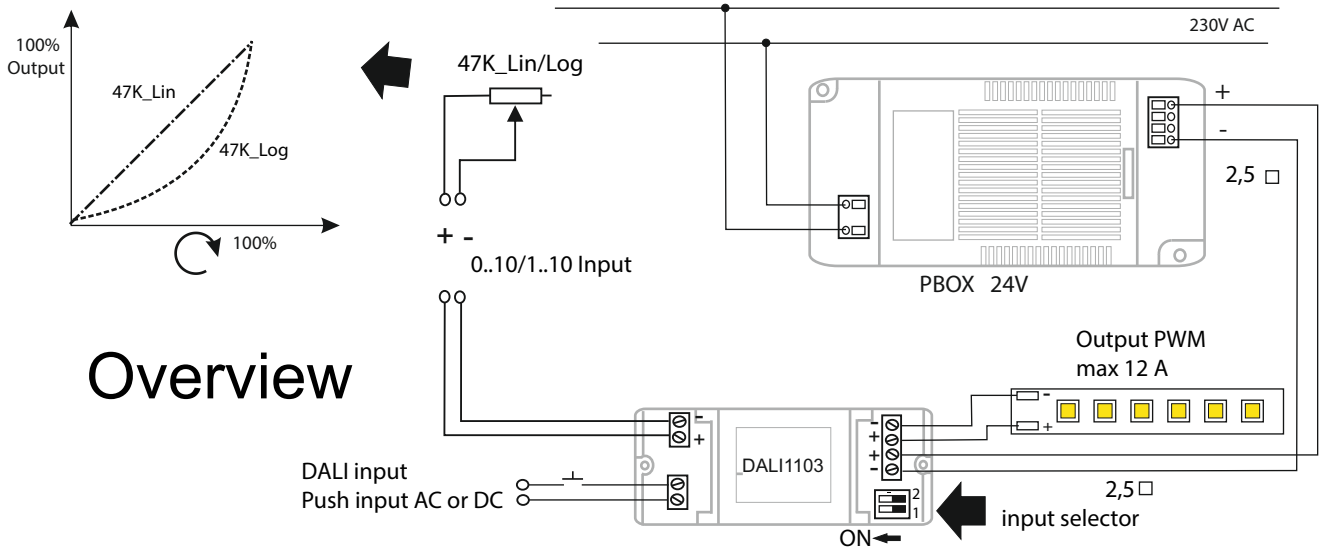

Overview

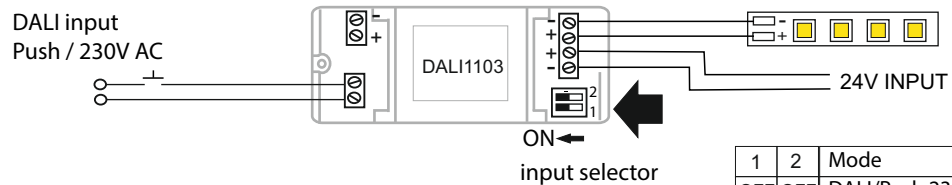

1	2	Mode
OFF	OFF	DALI/ Push 230V

DALI/ Push 230V

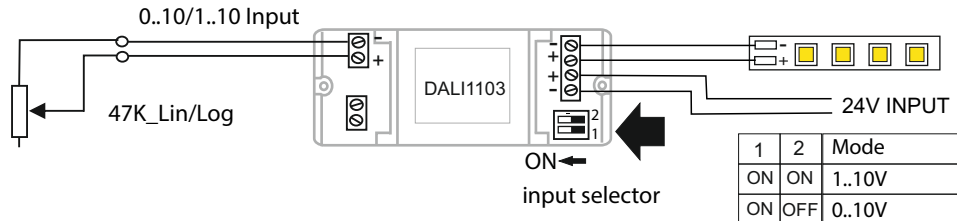

1	2	Mode
ON	ON	1..10V
ON	OFF	0..10V

1..10V input

input selector

1	2	Mode
OFF	OFF	DALI/ Push 230V
OFF	ON	Push 24V
ON	OFF	0..10V
ON	ON	1..10V

cambio impostazioni ad apparecchio spento

Settings can be changed ONLY when the device is OFF

Eteindre l'appareil pour changer les programmations.

Wechsel der Einstellungen nur wenn das System OFF ist.

La configuración se puede cambiar SOLAMENTE cuando el dispositivo está APAGADO



EE 99%	LED	PF λ0,99	Dimm DALI/Push/1..10/0..10
Pno 0,4W	Psb 0,4W	Pnet 0,4W	Load Always ON
			IP 20

Carico minimo: Push/ 1_10/0_10 1W , Carico minimo DALI2 Vedi etichetta
 Min. load with PUSH/1-10V/0-10V control: 1W Min. load with DALI2 control: see product label
 Mindestlast mit Steuerung PUSH/1-10/0-10V: 1W Mindestlast mit Steuerung DALI2: laut Produktsanschrift
 Charge minimale avec contrôle PUSH/1-10/0-10V: 1W Charge minimale avec contrôle DALI2: voir étiquette
 Carga minima para el control PUSH/1-10/0-10V: 1W Carga minima para el control DALI2: ver etiqueta

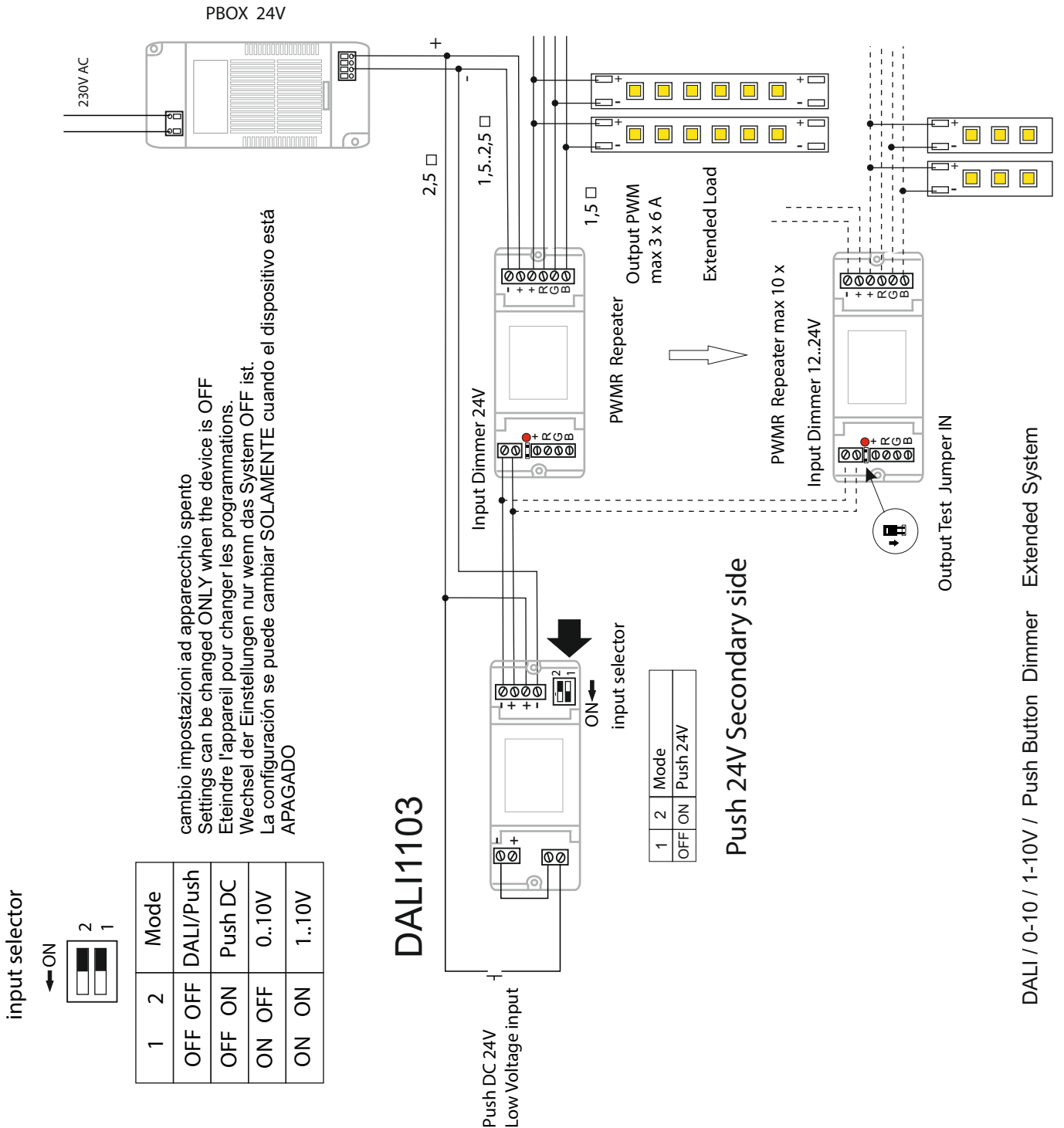

cambio impostazioni ad apparecchio spento
 Settings can be changed ONLY when the device is OFF
 Eteindre l'appareil pour changer les programmations.
 Wechsel der Einstellungen nur wenn das System OFF ist.
 La configuración se puede cambiar SOLAMENTE cuando el dispositivo está APAGADO

DALI / 0-10 / 1-10V / Push Button Dimmer Extended System

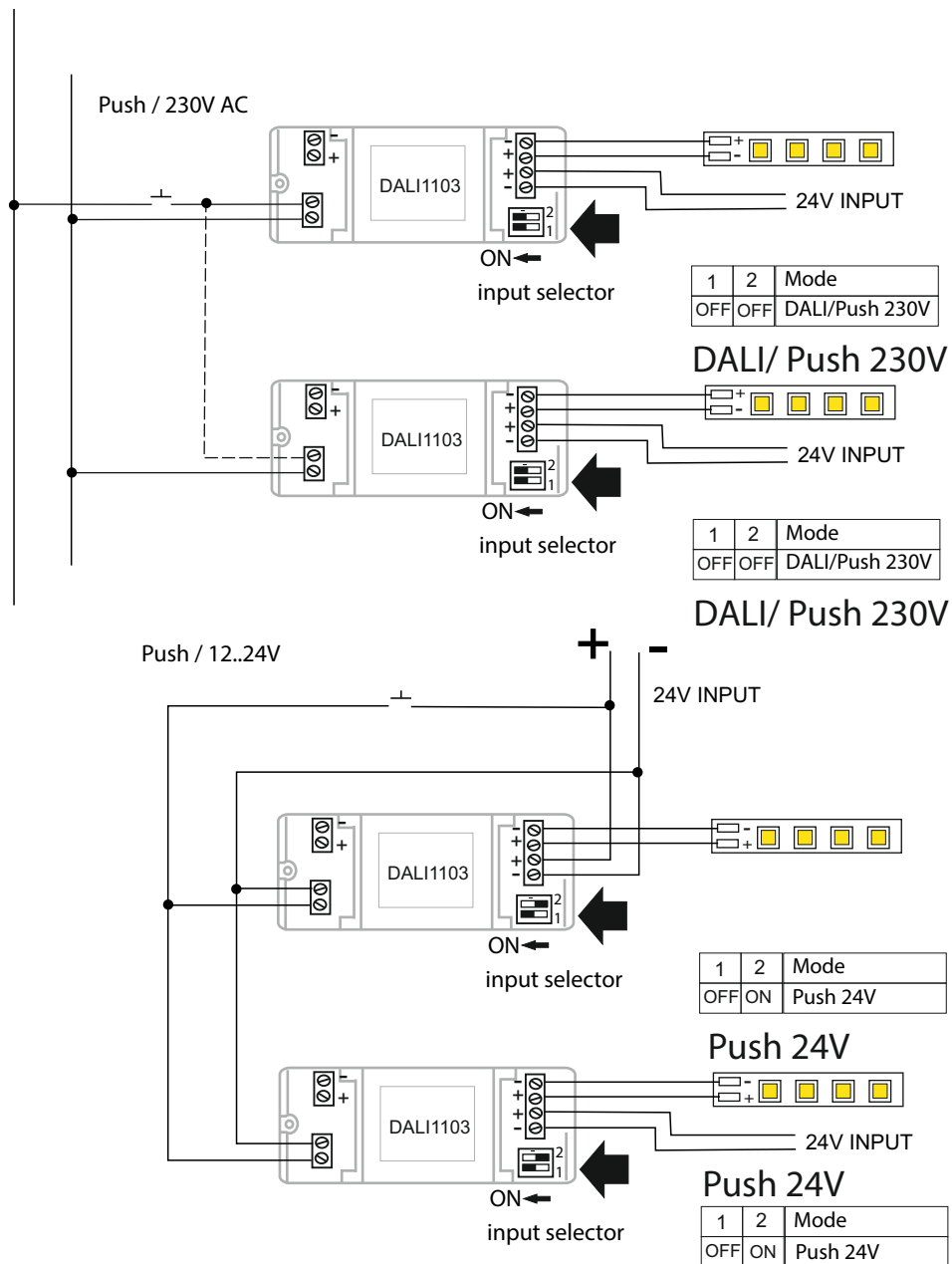

Pressione prolungata del pulsante per sincronizzare l'impianto in caso di differenze nei livelli di luminosità

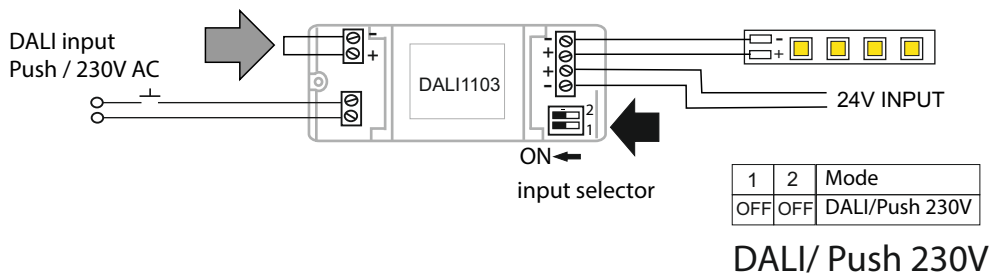

In caso di problemi con sistemi domotici DALI , sistemi DALI1 , segnalazione di guasti inesistenti

In caso di carico diverso dalle strisce LED standard , esempio lampadine ,strisce con regolatori a corrente costante Si possono escludere alcune funzioni comunicando con master in modo semplificato ed eludere problematiche.

- 1)Spegnere l'apparecchio, configurare su DALI i dip Switch (OFF OFF) .
- 2)Creare un collegamento come evidenziato, Riaccendere l'apparecchio in modalità semplificata

In case of problems with DALI home automation systems, DALI1 systems, reporting of non-existent faults

In case of load different from standard LED strips, for example LED bulbs

Some functions can be excluded by communicating with the master in a simplified way and avoiding problems.

- 1)Turn off the device, set the dip switches to DALI mode (OFF-OFF) .
- 2) Create a connection as highlighted, switch the device on again in simplified mode